

HSF RoHS

SPECIFICATIONS

Rated Current: 3.0AMP
 Contact Resistance: 20mΩ Max
 Withstand Voltage: 1000V AC/DC
 Insulation Resistance: 1000MΩ Min
 Operation Temperature: -40°C to +105°C

Contact Material: Brass
 Contact Plating: Au or Sn Over Ni
 Insulator Material: Polyester (UL94V-0)
 Standard: PA66

注明: 带号码球的为重点尺寸

Ordering Information

JL2541S - XX B XX X X 01

| | | | | | |
|--------|------------------------------|--|---|---------------------------------------|---|
| S=180° | No. of Pins Per Row 2-16P | Insulator Material Option B=BK-PA66 | Contact Plating G0: Gold Flash G1: 1U" Gold G2: 1.5U" Gold G3: 2U" Gold G4: 3U" Gold G5: 5U" Gold G6: 10U" Gold S0: Gold Flash/Tin SN: Tin | Insulator Color W=White E=Beige | Packing O=PE Bag A=Tray T=Tube |
|--------|------------------------------|--|---|---------------------------------------|---|

Recommended P.C.B Layout (Top Side)
 (PCB BOARD TOLERANCE ±0.05)

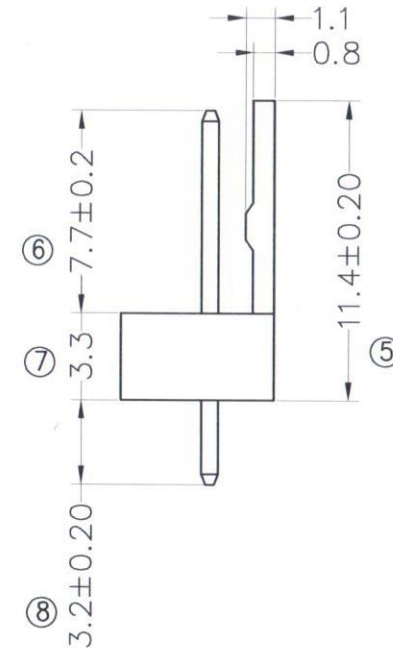
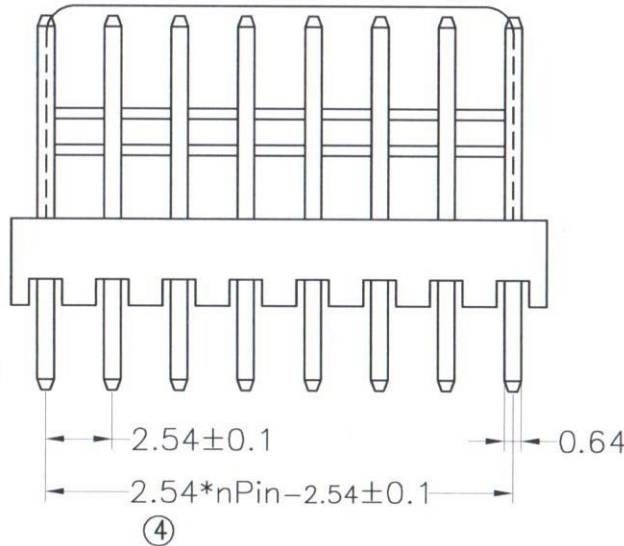
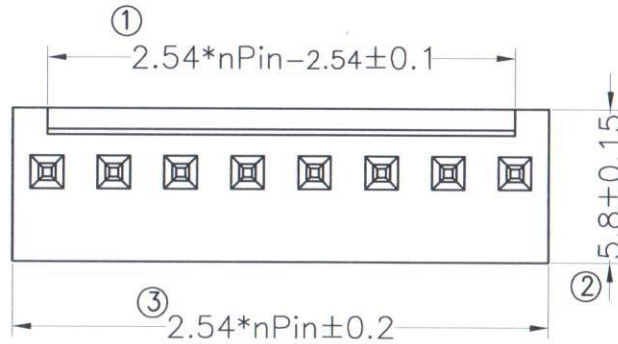
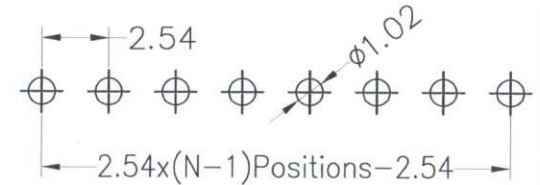

OPERATION

| | |
|-------|-------|
| X.X | ±0.30 |
| X.XX | ±0.20 |
| X.XXX | ±0.10 |
| Angle | ±3° |
| DIM | TOL |

DRAW

CHECK

APPROVE

YiYuSheng

12.03.28

SCALE

UNIT

SIZE

SHEET

PROJ.

FIT

mm

A4

1/1

◆

JiLN® 深圳市锦凌电子有限公司
 SHENZHEN JINLING ELECTRONIC CO., LTD
 Tel: 86-755-2997-5806/5802 Fax: 86-755-2997-5992

PART NO.

DS1070 series

TITLE:

2.54 Wafer M-Type Npin 180°

A0 2012.03.28 NEW DRAWING

REV DATE MODIFICATION DESCRIPTION CHANGE